

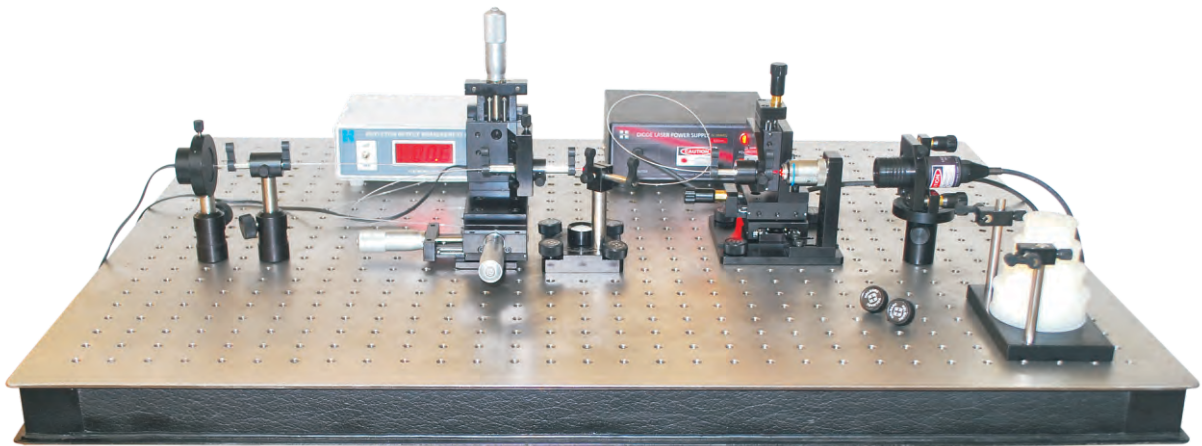

# Instruction Manual



## Optical Fiber Characterization Apparatus (Breadboard Based)

Model: HO-ED-F-03

## CONTENT

Page

Product Features .....	01
Getting Started .....	01
Quick Start .....	01
Installation & Safety Instructions .....	02
Experiments Included .....	02
Study of total internal reflection & calculation of refractive index of PMMA rod .....	02
Multimode mode Fiber Characterization .....	06
Single mode Fiber Characterization .....	22
Components Included with Specifications .....	30
Maintenance Notes .....	36
Technical support .....	36
Feedback .....	36
Mechanical Drawing .....	38

## Product Features

Holmarc's **Optical Fiber Characterization** is an educational apparatus for studying numerical aperture, bending loss etc. of an optical fiber. The use of optical breadboard makes the system flexible and helps to setup many other experiments and projects if needed. One can perform the following experiments using this apparatus.

1. Study of total internal reflection and calculation of refractive index of PMMA rod.
2. Determination of numerical aperture, bending loss and Splice Loss of a given multimode optical fiber.
3. Determination of numerical aperture, mode field diameter and V number of a given single mode fiber.

## Getting Started

### a. Quick Start

Please check if the following items are present while the instrument package is delivered.

- |  |   |
|--|---|
| 1. Optical Bread board with rigid support - 1 No.                  |   |
| 2. Kinematic Laser Mount - 1 No.                                   |   |
| 3. Diode laser With Power Supply - 1 No.                           |   |
| 4. Pinhole detector with O/P Measurement unit - 1 No.              |   |
| 5. Laser - Fiber Coupler with multi axis translation stage - 1 No. |   |
| 6. Cell Mount - 1 No.  |   |
| 7. Fiber chuck holder - 1 No.                                      | 11. Rotation stage with fiber chuck - 1 No. |
| 8. XYZ translation stage - 1 No.                                   | 12. Multimode fiber - 2 types (5m each)     |
| 9. Bending loss apparatus - 1 No.                                  | 13. Single mode fiber - 3m                  |
| 10. Fiber chuck - 1 No.  | 14. PMMA rod with mount - 1 No.             |

## b. Installation & Safety Instructions

- Laser radiation predominantly causes injury via thermal effects; avoid looking directly into the laser beam.
- It is recommended that students work in low light dust free atmosphere.
- Care must be taken while handling the Optical fiber.
- Always keep the equipment in a moisture and dust free atmosphere.

### Study of total internal reflection & Calculation of refractive index of PMMA rod

Total internal reflection is an optical phenomenon that happens when a ray of light strikes a medium boundary at an angle larger than critical angle with respect to the normal to the surface. If the refractive index is lower on the other side of the boundary and the incident angle is greater than the critical angle, no light can pass through and all of the light is reflected.

**Aim :** To find the refractive index of a transparent solid using diode laser.

#### Parts Listing :

1. Kinematic Laser mount
2. Diode Laser
3. Power Supply for laser
4. Mount for PMMA rod
5. PMMA rod

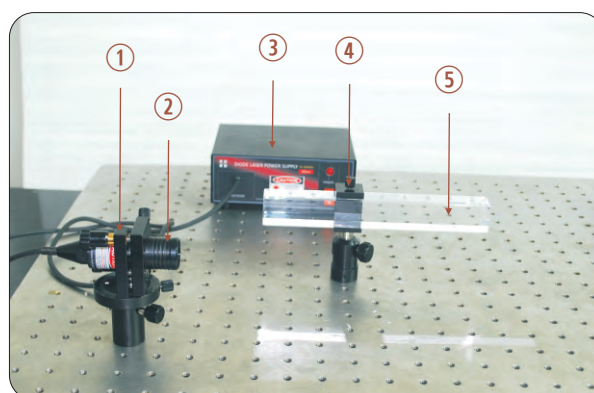

**Theory :** According to Snell's law,

$$n = \sin i / \sin r$$

where,  $n$  is the refractive index of transparent medium, ' $i$ ' is the angle at which light enters the medium and ' $r$ ' is the angle at which it gets refracted.

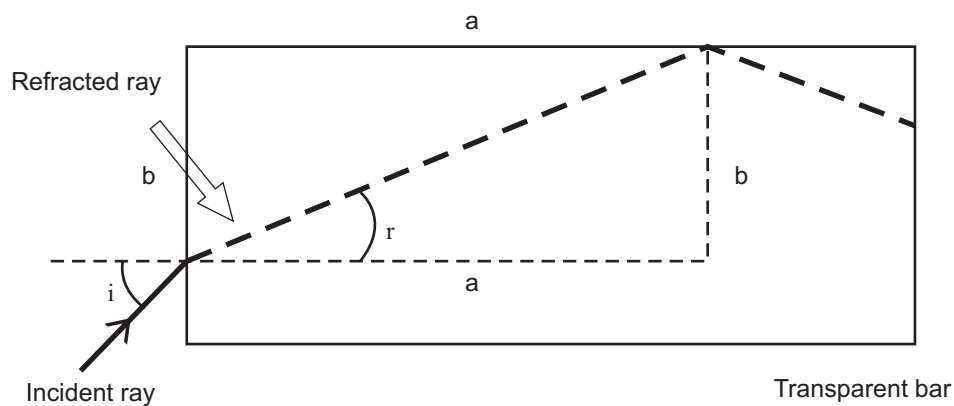
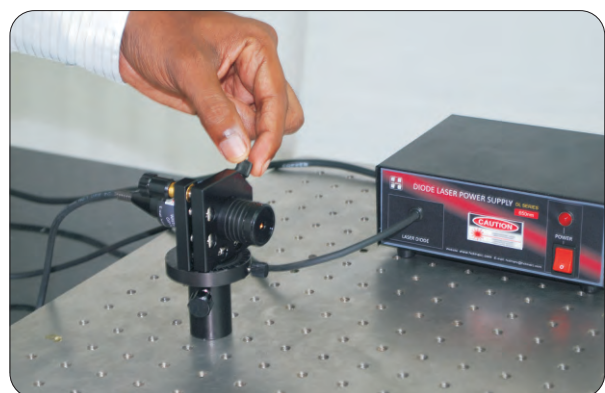

Figure (1)

### Experimental Set-up :

1. Fix the kinematic laser mount on the bread board and mount the laser properly.



2. Mount the PMMA rod on the optical bread board.

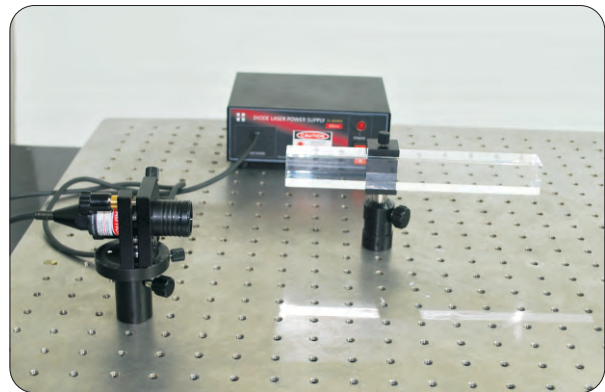
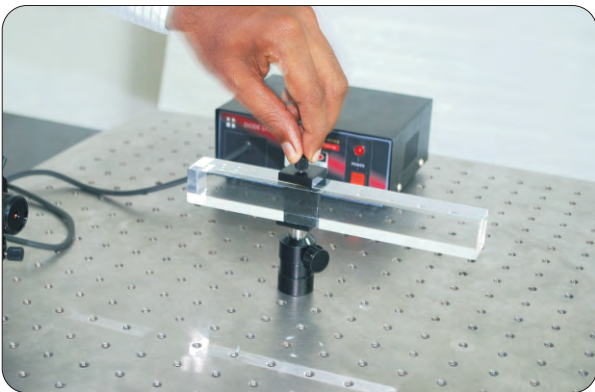

**Procedure :**

1. Make sure that the laser beam is exactly parallel to the PMMA rod. Rotate laser so that beam falls on the PMMA rod at an angle as shown in the figure. Fine adjustment can be done to get the angle for total internal reflection.

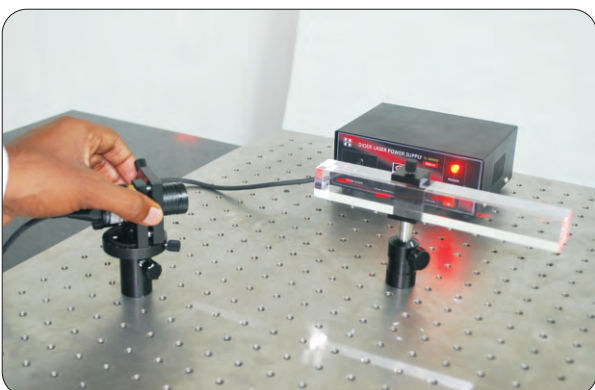

2. Note down incident angle of laser beam directly from the dial on laser mount. Measure the distances **a** and **b** using a meter scale. (Refer figure 1)

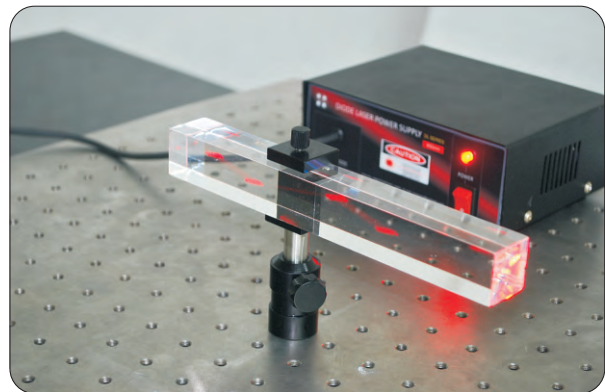
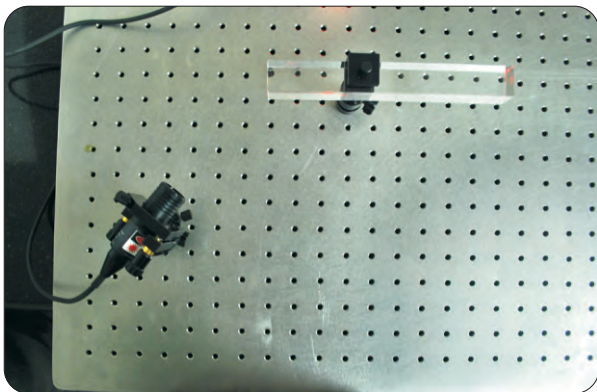

3. Repeat the experiment by changing the angle of incidence.

**Measurements :**

Trial No:	Angle of incidence (i)	a cm	b cm	$r = \text{Tan}^{-1} (b/a)$	Sin r	Sin i	$n = \sin i/\sin r$

Mean refractive index n = .....

**Result :**

The refractive index of the solid n = .....

## Multimode Fiber Characterization

### Aim :

1. To determine numerical aperture of a given optical fiber.
2. To study the bending loss in a multimode optical fiber.
3. To determine Splice Loss
  - a. Transverse offset between the fiber ends.
  - b. Longitudinal separation between the fiber ends.
  - c. Angular tilt between the fiber ends.

### Parts Listing :

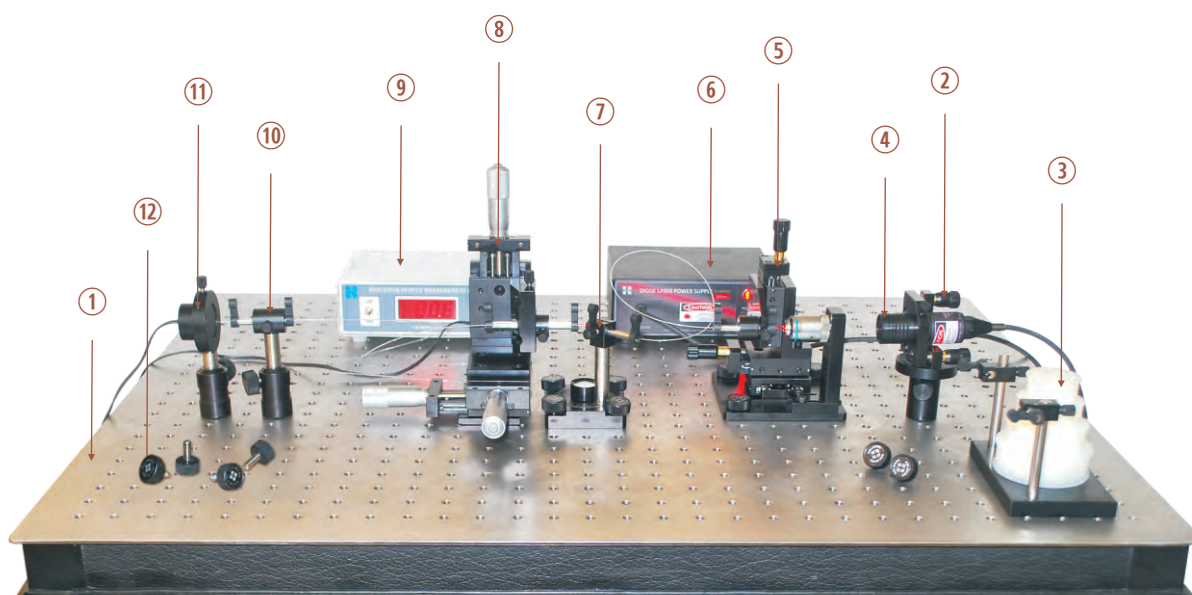

- |  |  |
|--|--|
| 1. Optical Bread board with rigid support                  | 6. Laser Power Supply                    |
| 2. Kinematic Laser Mount                                   | 7. Rotation stage with fiber chuck       |
| 3. Bending loss apparatus                                  | 8. XYZ translation stage                 |
| 4. Diode laser   | 9. Pinhole detector o/p Measurement unit |
| 5. Laser-Fiber Coupler with multi axis - translation stage | 10. Fiber chuck holder                   |
|  | 11. Cell Mount with pinhole detector     |
|  | 12. Thumb screws                         |

## ❑ Numerical Aperture

### Theory :

A multi-mode optical fiber will only propagate light that enters the fiber within a certain cone, known as the acceptance cone of the fiber. The half-angle of this cone is called the acceptance angle,  $\theta_a$ .

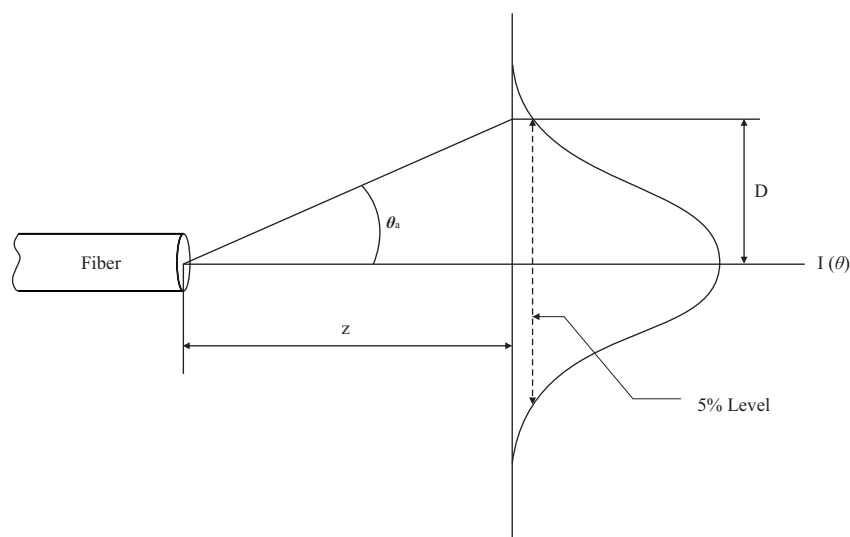

Acceptance angle

$$\theta_a = \tan^{-1} (D/Z)$$

where, **D** is the diameter of far field intensity at 5% intensity level of the maximum attainable intensity and **Z** is the distance between the detector and the fiber output end.

The Numerical Aperture is given by,

$$NA = \sin \theta_a$$

### Experimental Set-up :

1. Fix the kinematic laser mount on the optical breadboard and mount the diode laser carefully. Then fix the laser fiber coupler properly using thumb screws.

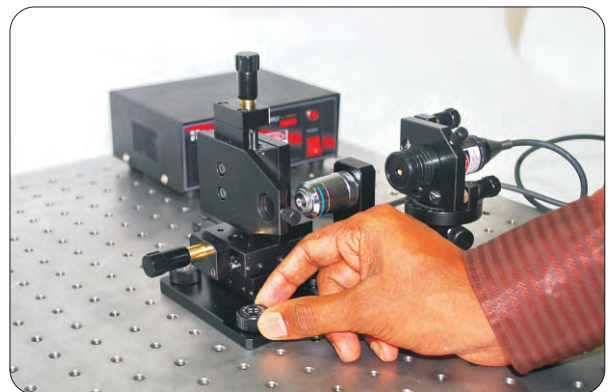
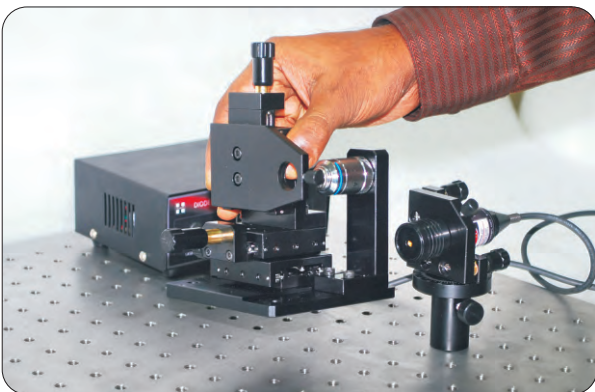
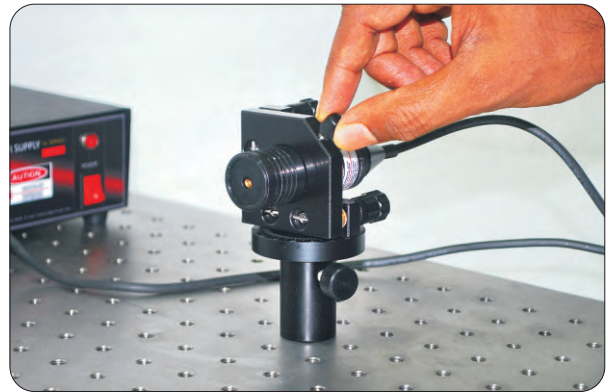

2. Fix one end of the optical on the chuck and mount it on the multi axis translation stage.

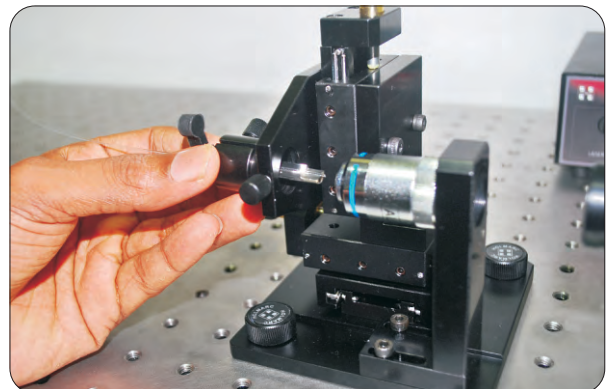

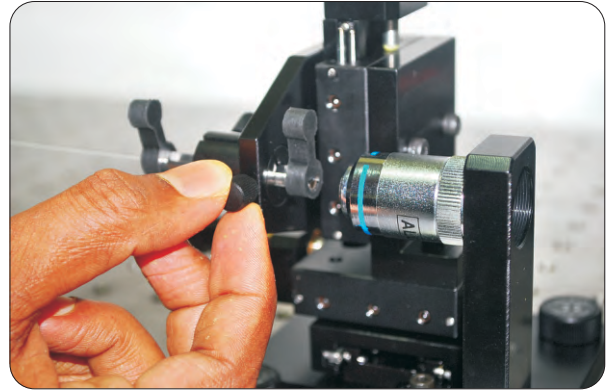
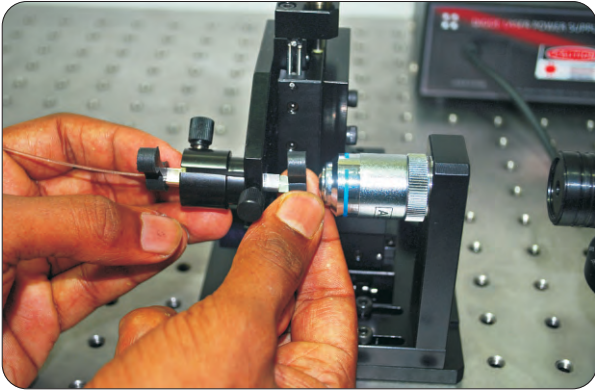

3. Mount the fiber chuck holder and insert the other end of the optical fiber and hold it as shown below.



4. Place XYZ translation stage and fix it on the bread board. Mount the pinhole photo detector on the stage.

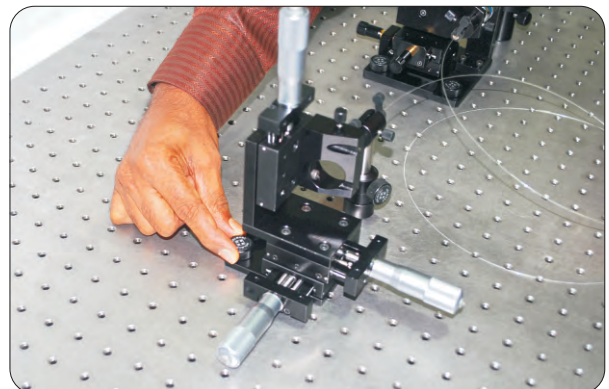
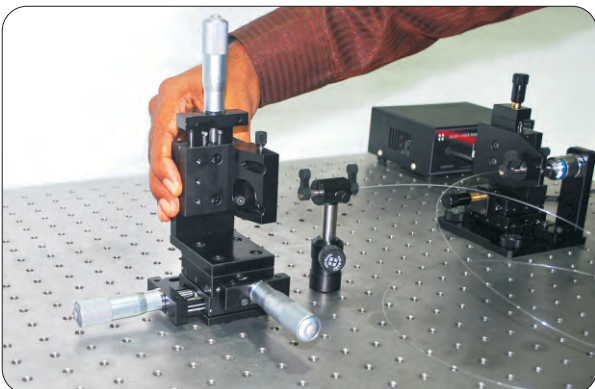

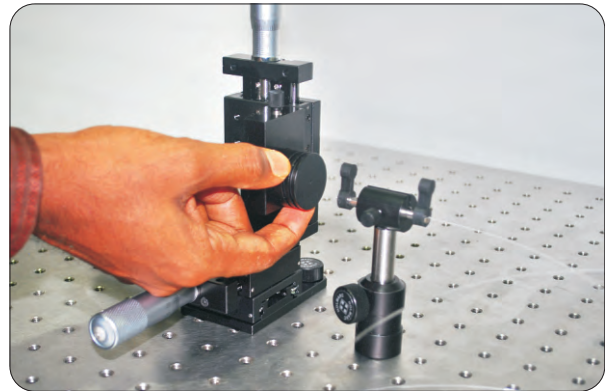
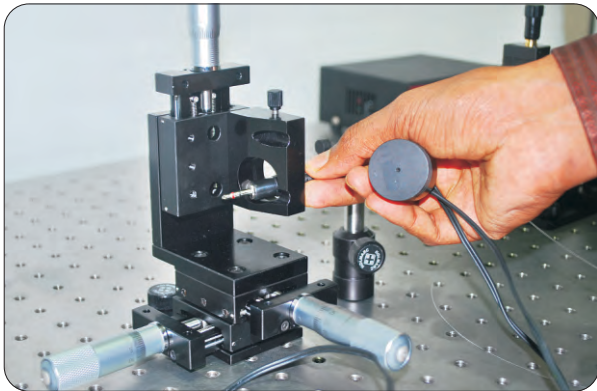

5. Switch on the laser and detector. The pinhole detector should be placed very close to the fiber tip. Using the multi translation stage and lead screws provided on the kinematic laser mount couple maximum light to the fiber.

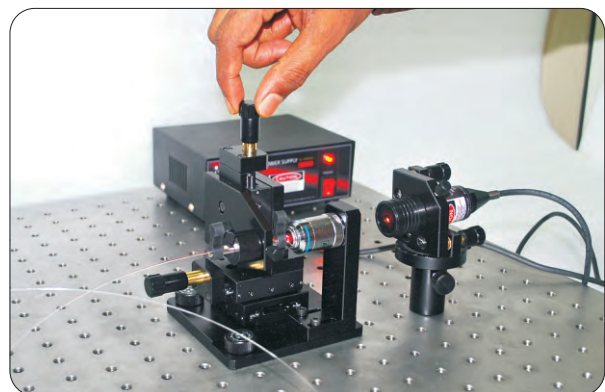
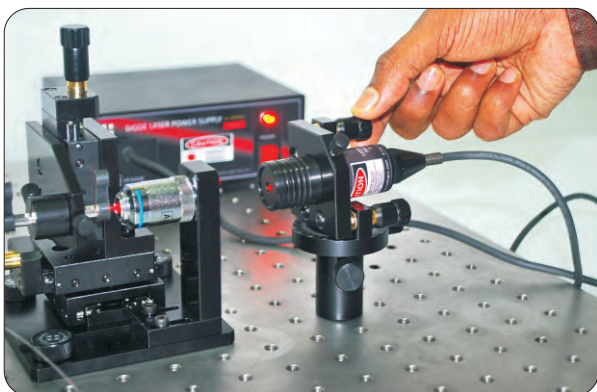

6. Make sure that the o/p from the fiber is maximum. For this move the detector in X and Y direction till the detector shows the maximum o/p current. After that adjust the diode laser using the lead screws and the laser fiber coupler till you obtain maximum current in the o/p measurement unit of the detector.

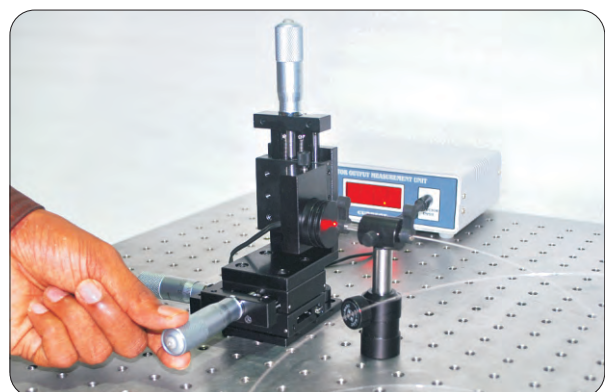
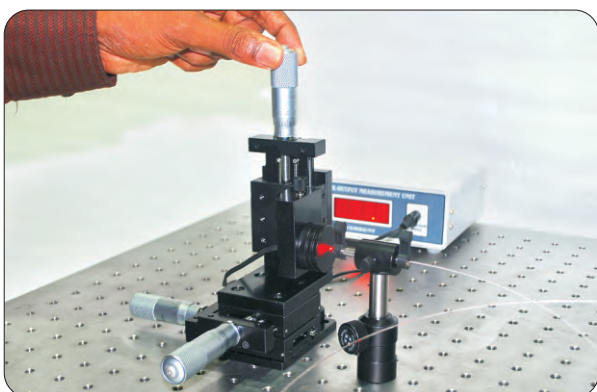

*Note: Change the range of the O/P measurement unit to  $\mu\text{A}$  from mA and vice versa whenever necessary.*

**Procedure :**

1. Bring the pinhole detector very close to the tip of the fiber using the Z micrometer provided on the translation stage, i.e. almost zero distance between the tip of the fiber and the pinhole detector. Note down the reading on the Z micrometer. Move the detector backwards using the Z micrometer (say 2 or 3mm) and again note down the reading. The difference between the two readings gives the 'Z'.

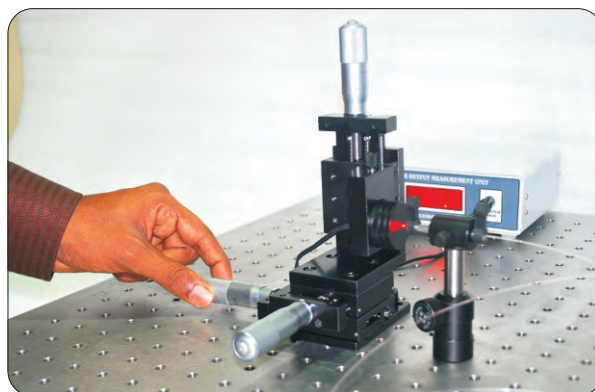

2. Move the detector to right or left extreme using the X micrometer. Then scan the entire beam in X direction. Each time note down the micrometer reading and o/p current from detector.

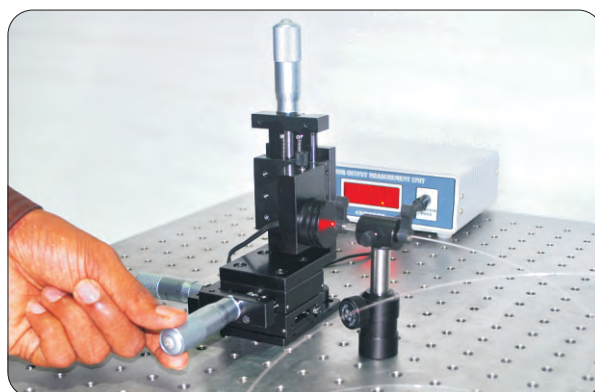

3. Plot a graph "micrometer reading versus o/p current". From the graph we can find D.

**Measurements :**

Least count of the micrometer = .....

SI No:	Micrometer reading (mm)	Detector o/p current

From graph,

Diameter of far field intensity at 5% intensity level of the maximum attainable intensity, D } = .....

Distance between the detector and the fiber output end, Z = .....

Acceptance angle,  $\theta_a = \tan^{-1} (D/Z) = \dots\dots\dots$

Then the numerical aperture is given by,

$$NA = \sin \theta_a = \dots\dots\dots$$

**Result :**

The Numerical Aperture of the given optical fiber, NA = .....

## ❖ Bending Loss

### Theory :

The bend of a fiber causes loss in transmittance and increase in attenuation as the angle of incidence decreases at the points where curved radius is too small and the condition of total internal reflection is not fulfilled. In this experiment an apparatus of varying radii is used to study the bending losses involved. When a fiber is bend specified number of turns on various diameters, loss occurs in accordance with the diameter and it can be seen that, the loss will increase with respect to the decrease in diameter.

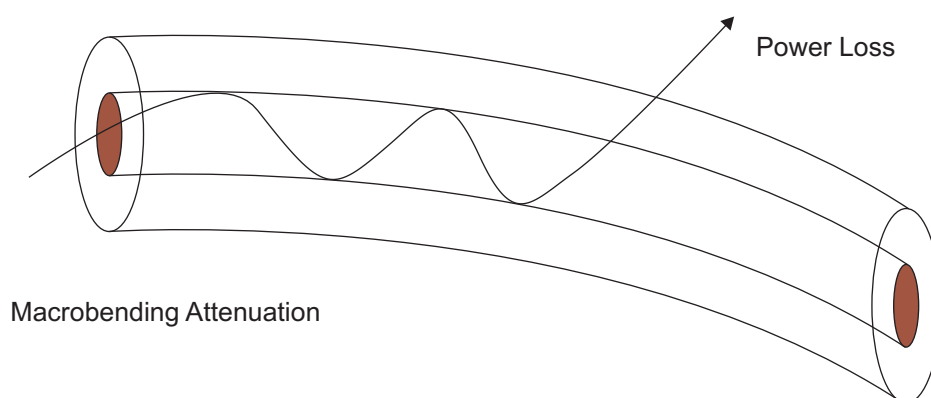

### Experimental Set-up :

1. XYZ translation stage in the above experiment (experiment to find the numerical aperture) and fix the cell mount. Mount pinhole photo detector on to cell mount.

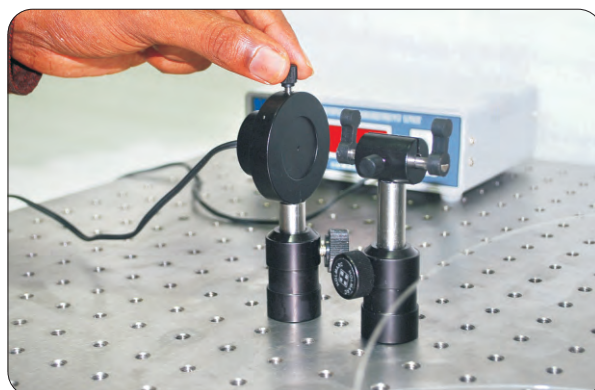

2. Place the bending loss apparatus in between the laser fiber-coupler and fiber chuck holder. For bending loss experiment we have to use a longer fiber. Fix the fiber to the bending loss apparatus as shown in figure. The end of the fiber connected at the laser - fiber coupler mount should not be disturbed while fixing the other end on the bending loss apparatus.



3. Wound the fiber on any of the circular diameter and connect the end to the fiber chuck holder fixed near the detector.

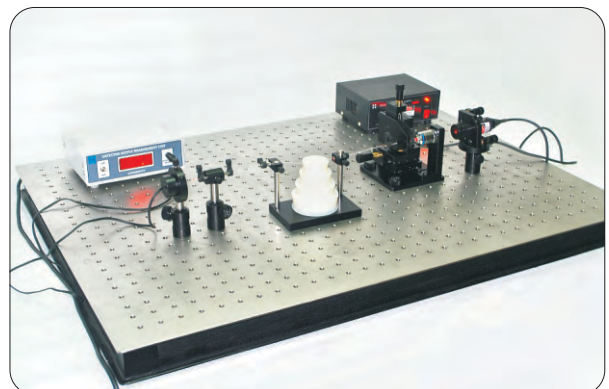
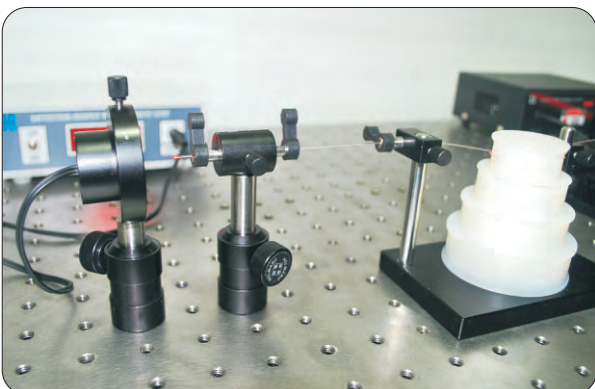
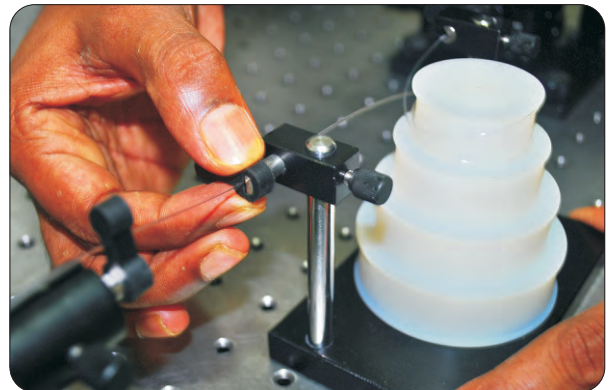

**Procedure :**

1. Take the output reading from the detector. Then increase the number of turns and take the corresponding readings. Repeat the experiment by changing number of turns or diameter.

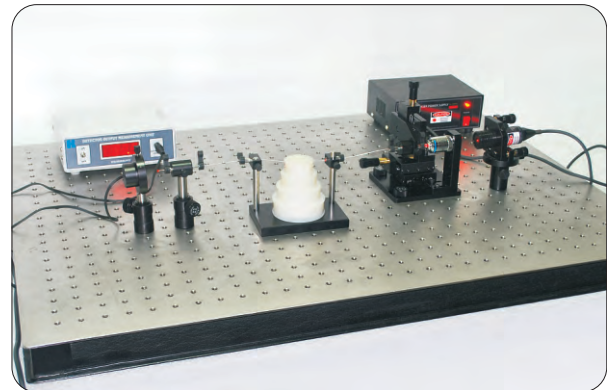

**Measurements :**

SI No:	Diameter (cm)	No. of turns (N)	O/P current from the detector ( $\mu\text{A}$ )

**Result :**

Observed the bending losses in a multimode fiber when it is bent along various diameter and found that the losses increase with decrease in diameter of bend.

## Splice Loss

### Theory :

Optical power loss at the splicing point of two ends of optical fiber is known as splice loss.

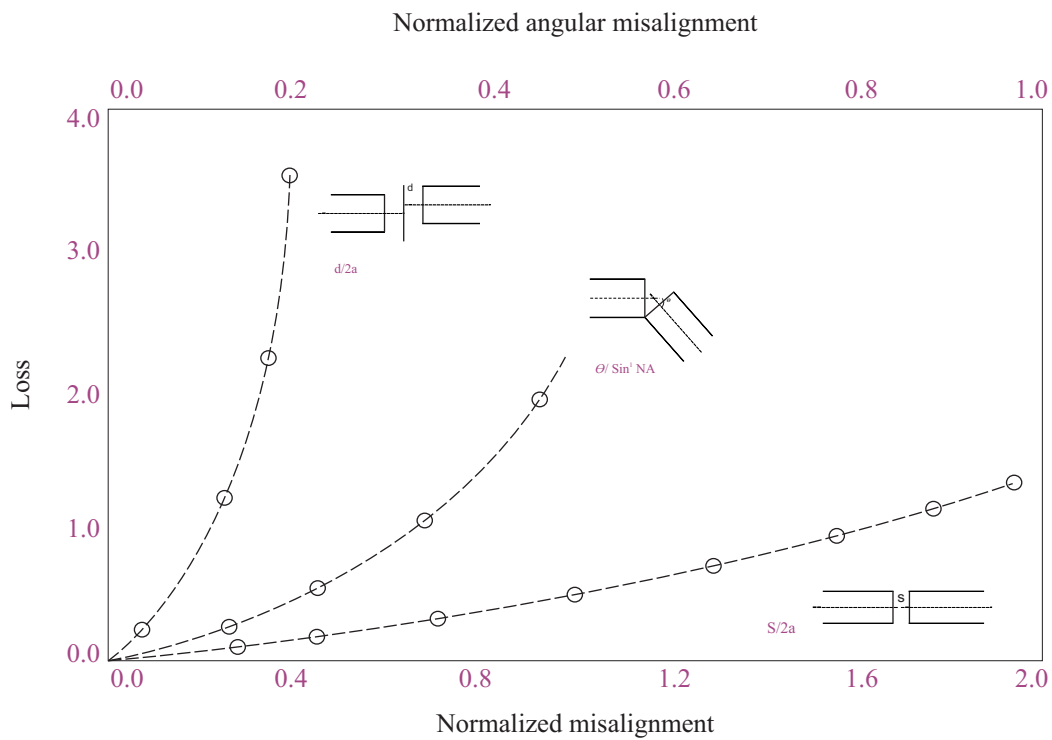
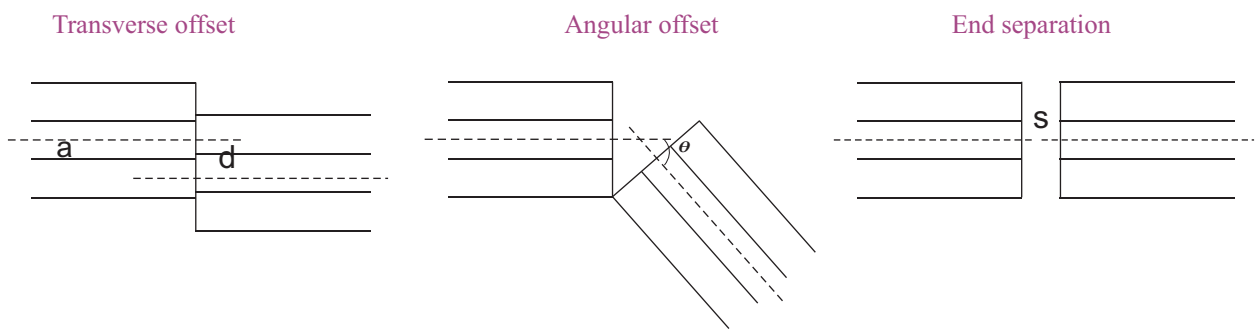

*Typical results of splice losses due to various offsets between two multimode fibers*

### Experimental Set-up :

1. Mount the laser on the breadboard using the laser mount and fix the laser-fiber coupler on the breadboard.

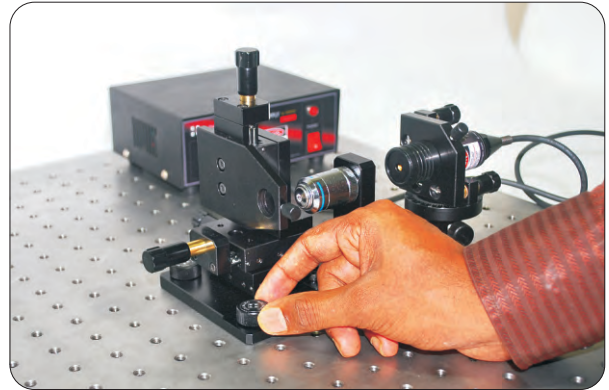
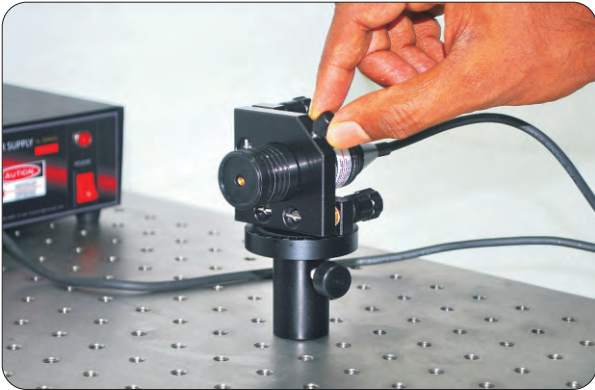

2. Fix one end of the optical fiber on the fiber chuck and mount it on the multi axis translation stage of the laser fiber coupler.

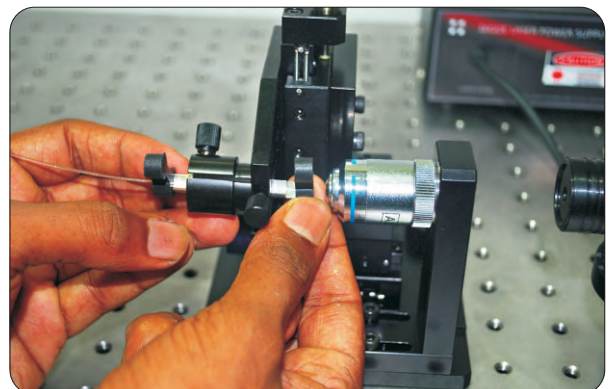
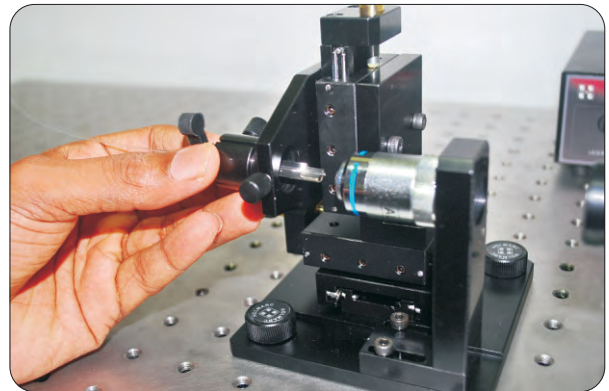
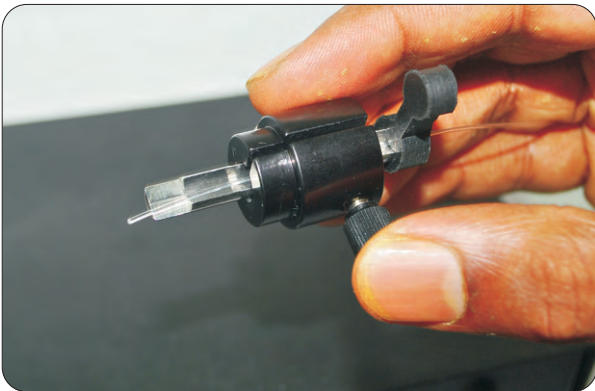

- Using thumb screws fix the rotation stage properly on the breadboard and fix the fiber on to it.

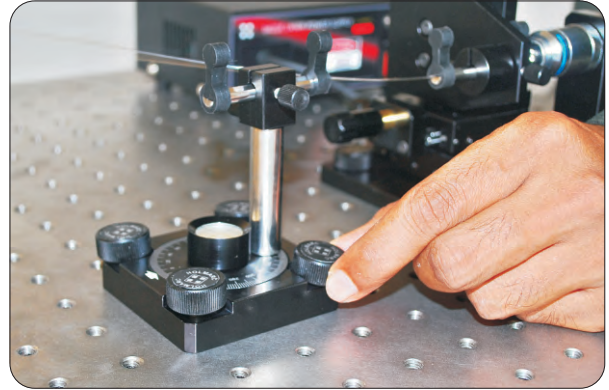

- Take another piece of fiber and fix it on the fiber chuck.



- Insert the chuck in the cell mount of the XYZ translation stage. The fiber end fixed on the rotation stage and the receiving fiber end on the XYZ translation stage must be very close to each other.

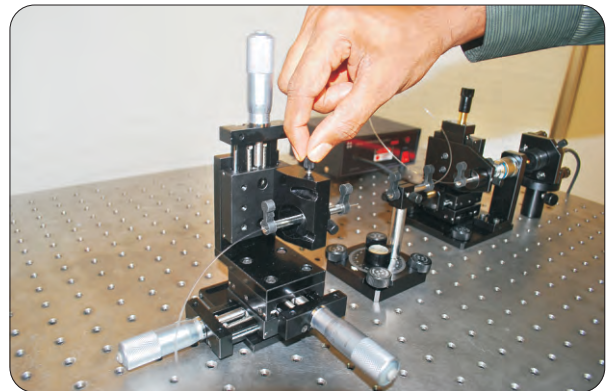
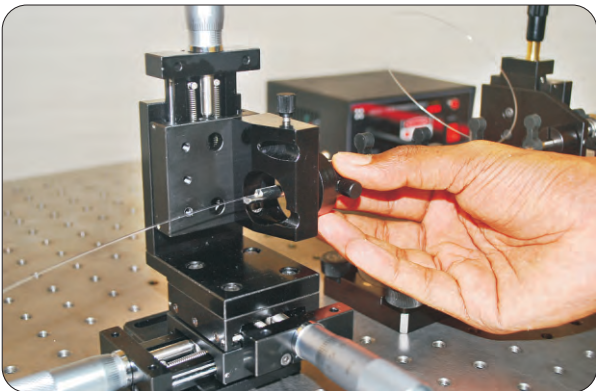

6. Fix the fiber chuck holder on the breadboard and mount the other end of the receiving fiber.



7. Place the cell mount and insert the pinhole photo detector.



### Procedure :

1. Switch on the diode laser and using the XYZ translation stage, laser fiber coupler and the tilt feature on the rotation stage obtain maximum output in the o/p measurement unit.
2. To study the loss due to misalignments caused in fiber, gradually move the receiving fiber end in longitudinal and transverse directions using the corresponding micrometers and note their outputs and also the micrometer readings. To study the loss due to angular misalignment, turn the rotation stage by small angles and note the corresponding readings.

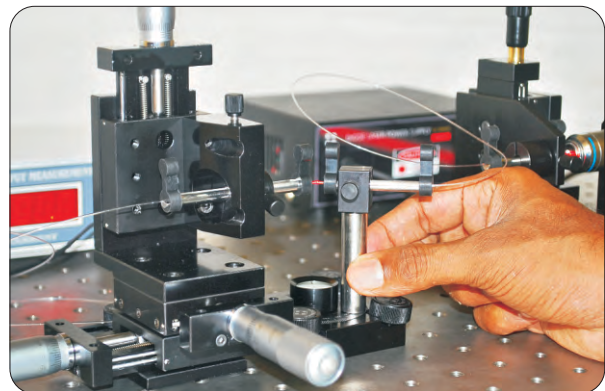
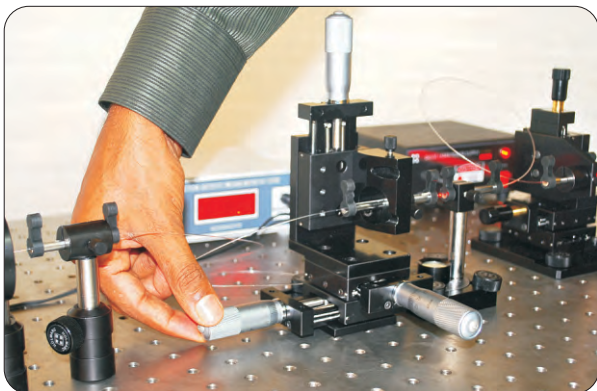
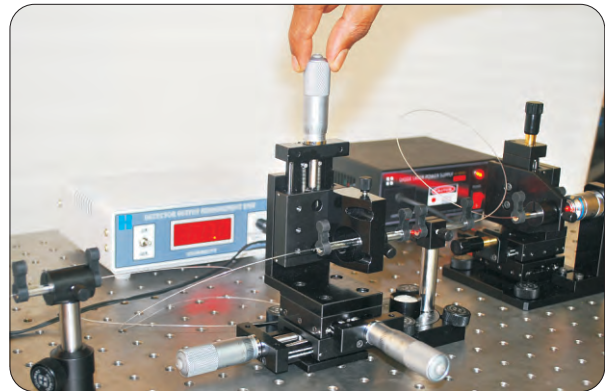
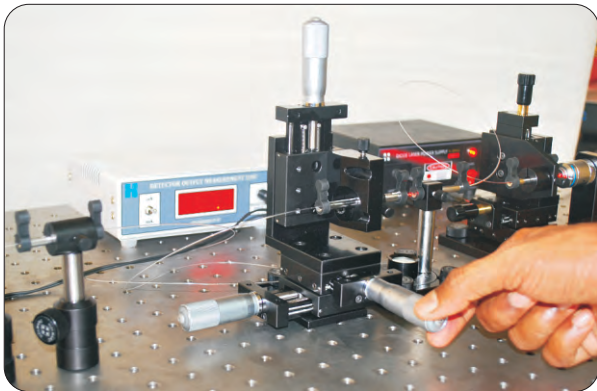

3. Now, plot the necessary graphs.

**Measurements :**

Transverse offset:

SI No:	Micrometer reading	Output current from the detector

Longitudinal offset:

SI No:	Micrometer reading	Output current from the detector

Angular Offset:

SI No:	Angle turned	Output current from the detector

**Result :**

Made comparative study of loss tolerance to various offsets between two fibers at a joint.

Observed that splice loss is most sensitive to transverse misalignments.

## Single mode Fiber Characterization

### Aim :

1. To determine the numerical aperture of a given optical fiber from the measurement on far field of the fiber and acceptance angle.
2. Calculation of normalized frequency or V-number.
3. Calculation of mode field diameter.

### Theory :

#### Numerical Aperture:

A single mode optical fiber will only propagate light that enters the fiber within a certain cone, known as the acceptance cone of the fiber. The half-angle of this cone is called the acceptance angle,  $\theta_a$ .

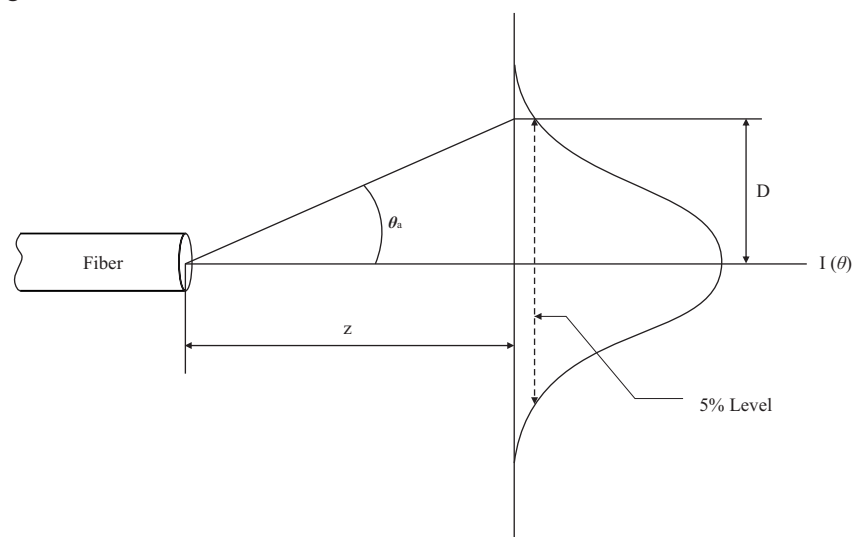

Acceptance angle

$$\theta_a = \tan^{-1} (D/Z)$$

where, **D** is the diameter of far field intensity at 5% intensity level of the maximum attainable intensity and **Z** is the distance between the detector and the fiber output end. The Numerical Aperture is given by,

$$NA = \text{Sin } \theta_a$$

**Normalized frequency:**

In an optical fiber, the normalized frequency, V (also called the V number), is given by

$$V = \frac{2\pi a}{\lambda} \sqrt{n_1^2 - n_2^2} = \frac{2\pi a}{\lambda} NA$$

Where **a** is the core radius,  $\lambda$  is the wavelength in vacuum, **n<sub>1</sub>** is the maximum refractive index of the core, **n<sub>2</sub>** is the refractive index of the homogeneous cladding, and applying the usual definition of the numerical aperture NA.

**Mode Field Diameter:-:**

For a Gaussian power distribution (lasers used in communications have Gaussian power distribution) in a single mode optical fiber, the mode field diameter (MFD) is defined as the point at which the electric and magnetic field strengths are reduced to 1/e<sup>2</sup> of their maximum values, i.e., the diameter at which power is reduced

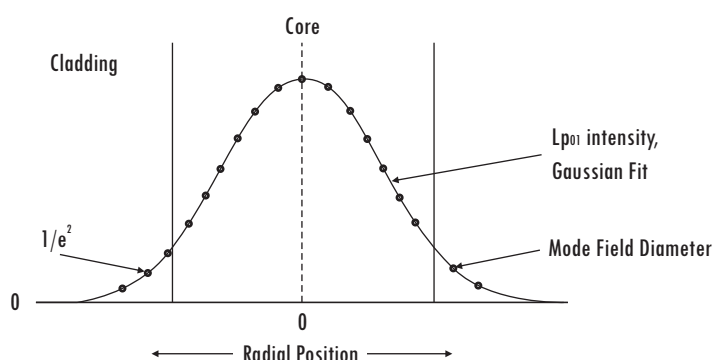

to 1/e<sup>2</sup> (0.135) of the peak power (because the power is proportional to the square of the field strength). For single mode fibers, the peak power is at the center of the core.

**Parts Listing :**

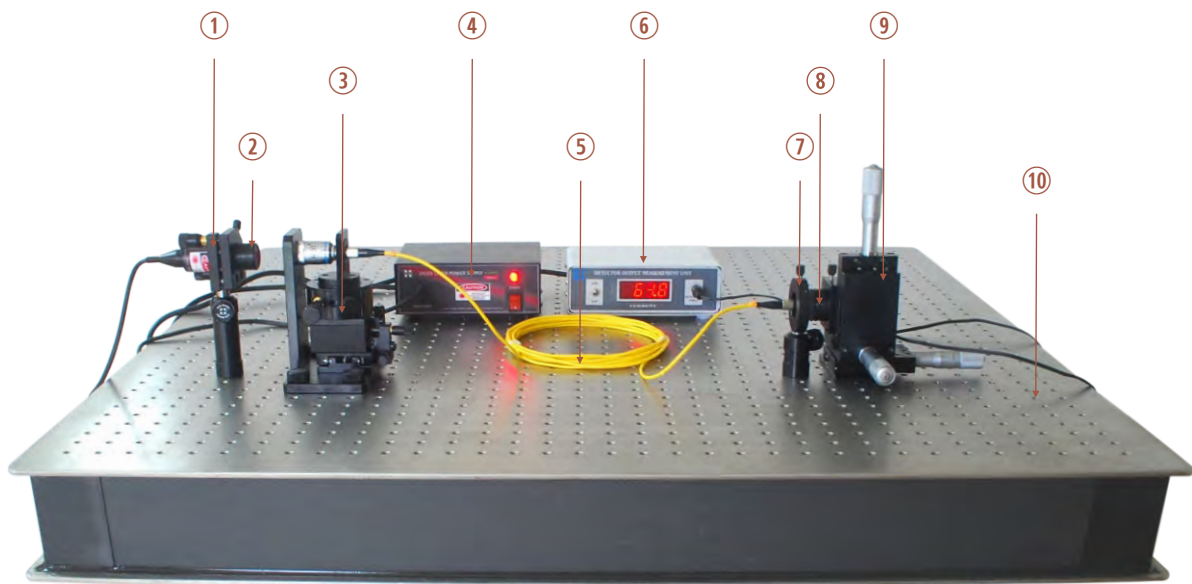

1. Kinematic Laser Mount
2. Diode laser
3. Laser-Fiber Coupler with multi axis translation stage
4. Laser Power Supply
5. Single Mode Fiber
6. O/P Measurement unit
7. Cell Mount with FC Connector Adapter
8. Pinhole detector
9. XYZ translation stage
10. Optical Bread board with rigid support

### Experimental Set-up :

1. Fix the Kinematic laser mount on the optical breadboard and mount the diode laser. Place the laser fiber coupler and fix it using thumb screws.

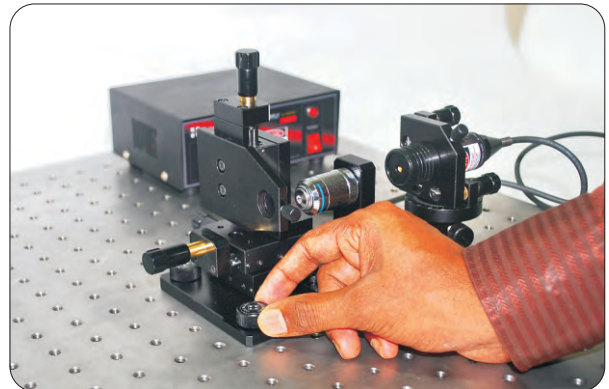
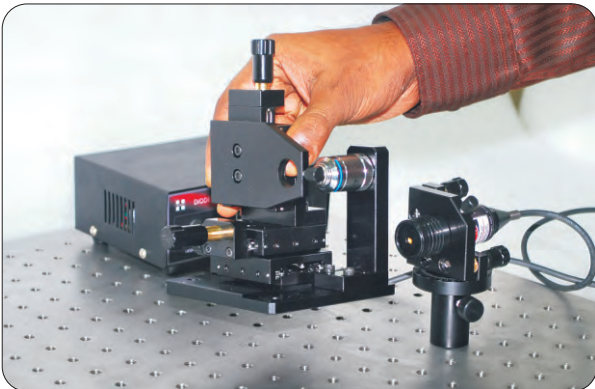
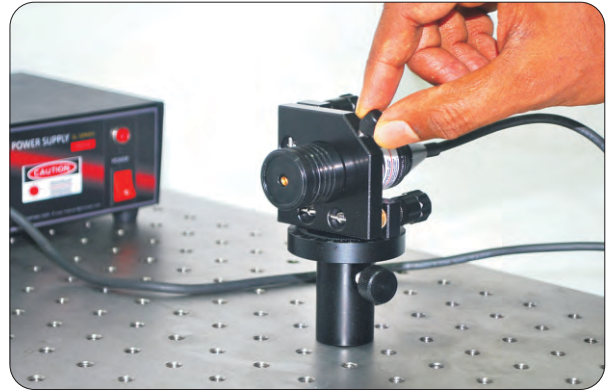
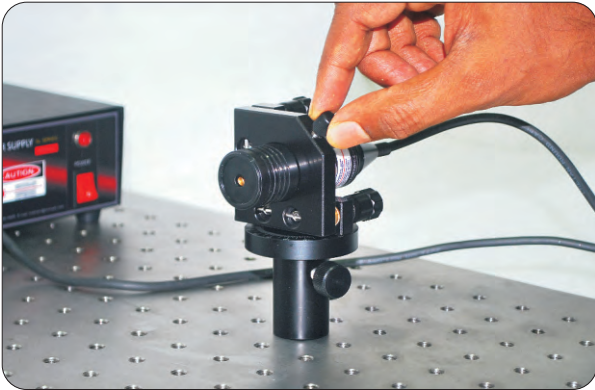

2. Mount the FC connector adapter on the laser fiber coupler carefully.

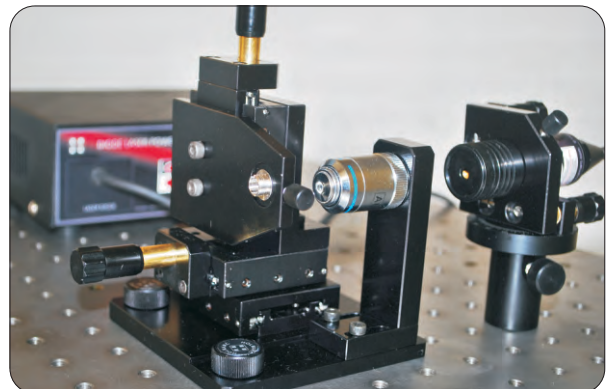
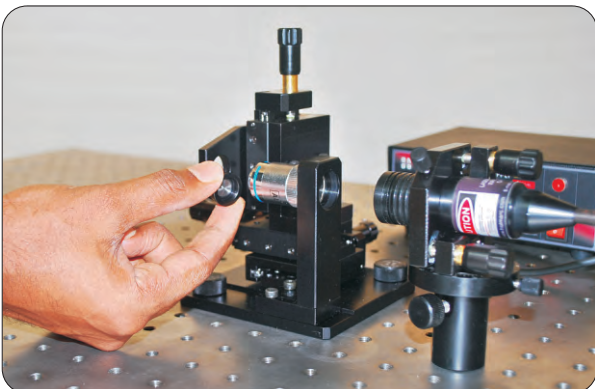

3. Connect one end of the single mode fiber to the FC connector adapter as shown below.

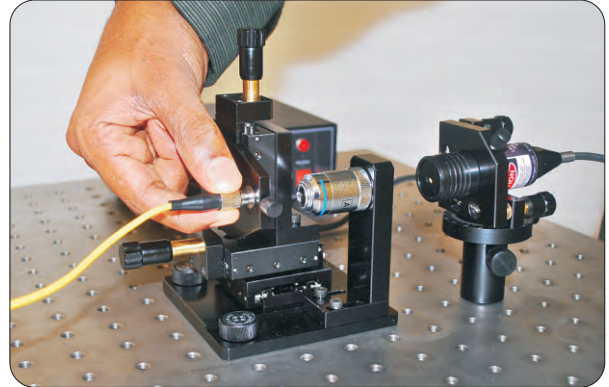
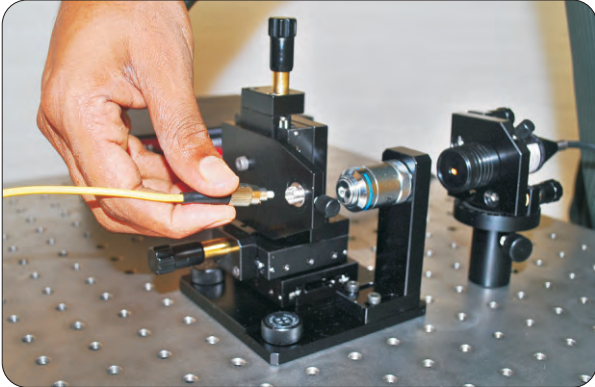

4. Fix the cell mount on the optical breadboard and mount the FC connector adapter properly. Then connect the fiber end.

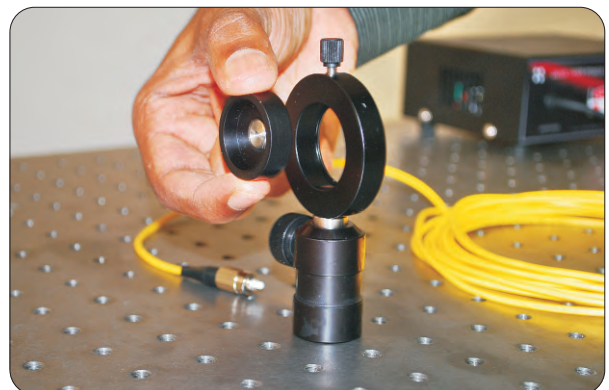

5. Place the XYZ translation stage and mount the pin hole photo detector.

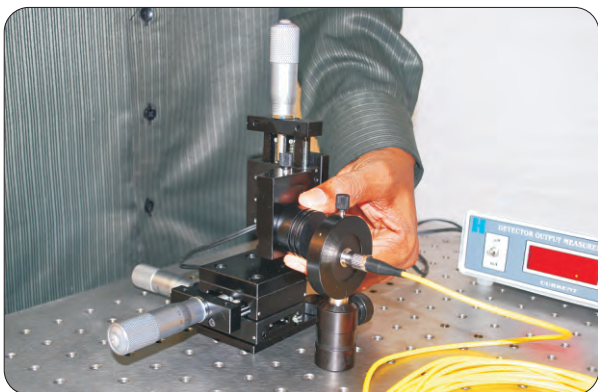
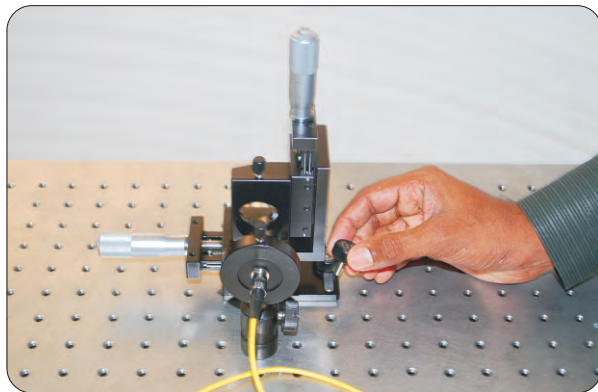

6. Switch on the laser and O/P Measurement unit. The pinhole detector should be placed very close to the fiber tip. Using the adjusting knobs on the laser fiber coupler translation stage, lead screws provided on the kinematic laser mount and micrometers on XYZ stage couple maximum light to the fiber.

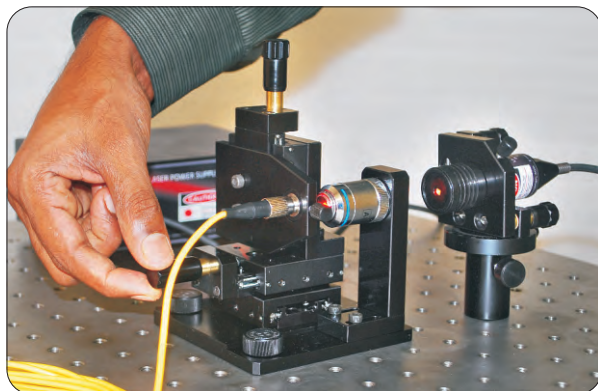
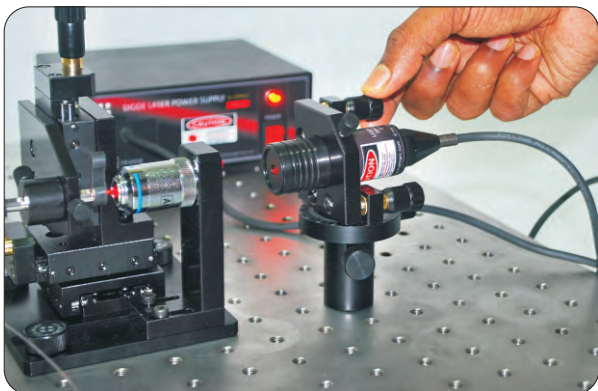

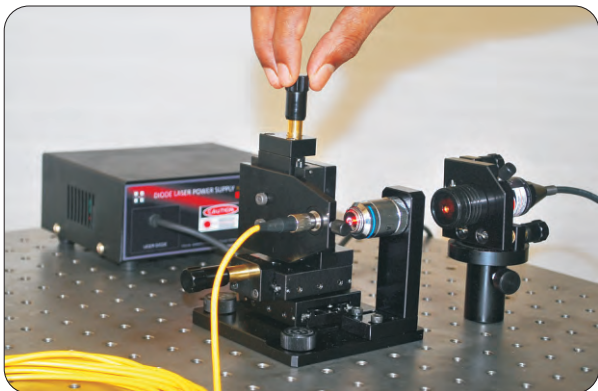

### Procedure :

1. Bring the pinhole detector very close to the tip of the fiber using the **Z** micrometer provided on the translation stage, i.e. almost zero distance between the tip of the fiber and the pinhole detector. Note down the reading on the **Z** micrometer. Move the detector backwards using the **Z** micrometer (say 2 or 3mm) and note down the reading. The difference between the two readings gives the '**Z**'.

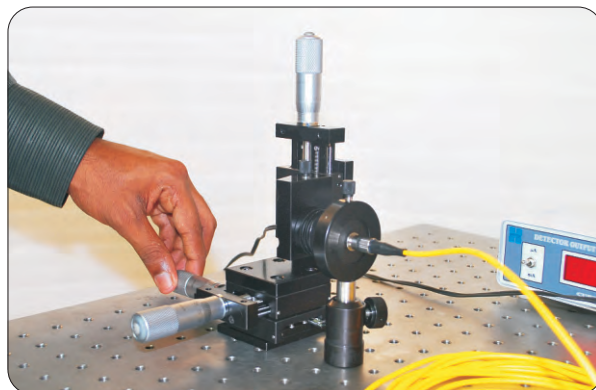

2. Move the detector to right or left extreme using the **X** micrometer. Then scan the entire beam in the **X** direction. Each time note down the micrometer reading and the O/P current from the detector.

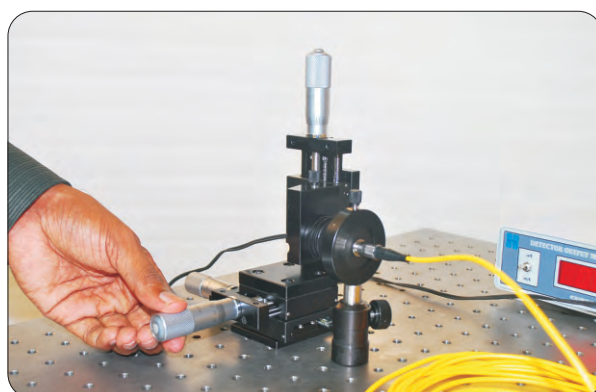

3. Plot a graph micrometer reading versus O/P current. From the graph we can find **D**.

**Measurements :**

Least count of the micrometer = .....

SI No:	Micrometer reading (mm)	Detector O/P current ( $\mu\text{A}$ )

From graph,

Diameter of far field intensity at 5% intensity level of the maximum attainable intensity, D } = .....

Distance between the detector and the fiber output end, Z = .....

Acceptance angle,  $\theta_a = \tan^{-1} (D/Z) = \dots\dots\dots$

Then the numerical aperture is given by,

$$NA = \sin \theta_a = \dots\dots\dots$$

Mode field diameter D =

V number is given by,

$$V = \frac{2\pi a}{\lambda} NA = \dots\dots\dots$$

where a is  $4.5\mu\text{m}$  for this fiber and  $\lambda$  is  $650\text{nm}$ .

**Result :**

The Numerical Aperture of the given optical fiber, NA = .....

Mode field diameter = .....

V number = .....

## ❑ Components Included with Specifications

### 1. Optical Bread Board with Support

Dimensions : 800mm x 600mm

Material : Stainless Steel



### 2. Kinematic Laser Mount

Fine adjustments : Using 80 tpi leadscrews

Adjustment Range : +/-4 degrees

Material : Black anodized Aluminum alloy

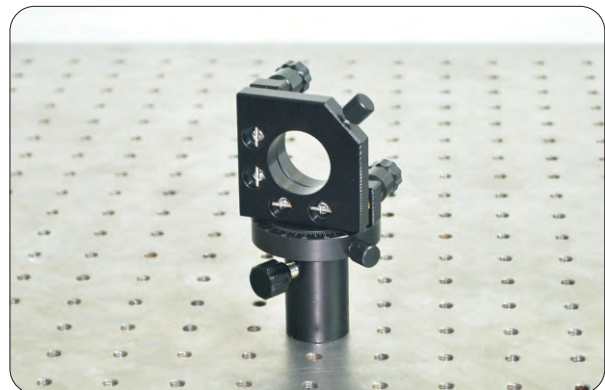

### 3. Cell Mount

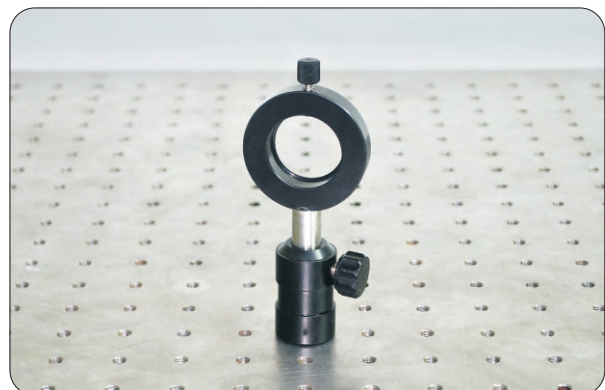

**4. PMMA Mount**

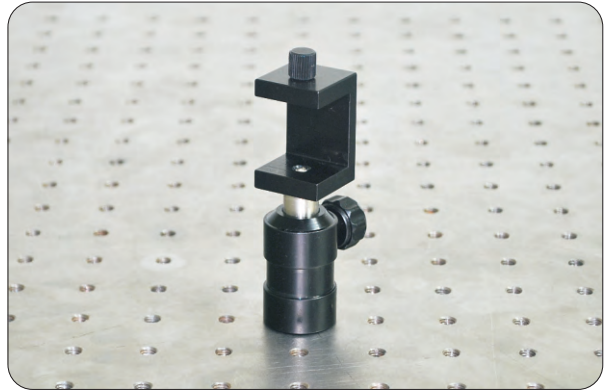

**5. Fiber Chuck holder**



**6. Fiber Chuck**

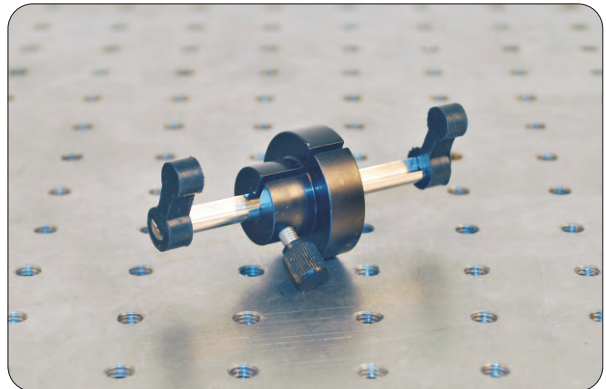

**7. Bending Loss Apparatus**

Diameters : 65mm, 55mm,  
45mm & 35mm

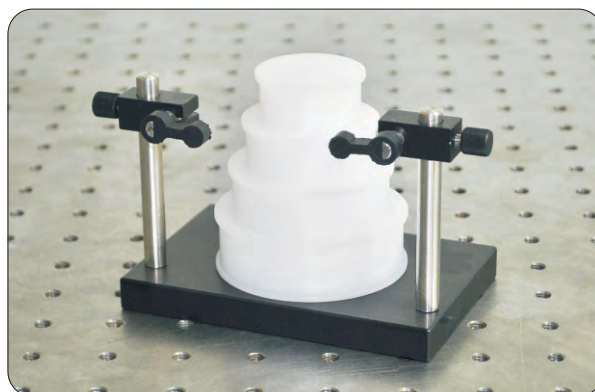

**8. Laser Fiber Coupler with multi translation stage**

Microscope objective : 10X

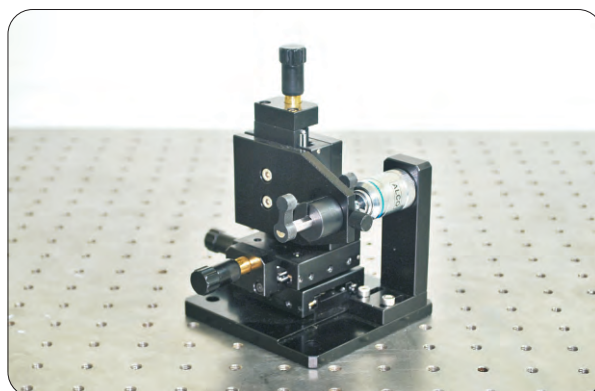

**9. XYZ Translation stage**

25mm travel in X, Y & Z directions  
Least count of the micrometer : 0.01mm

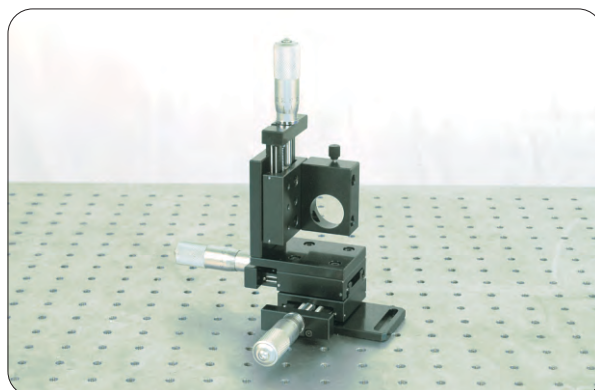

**10. PMMA ROD**

Dimensions : 20 cm X 2.5 cm X 2.5 cm  
Refractive Index : 1.5

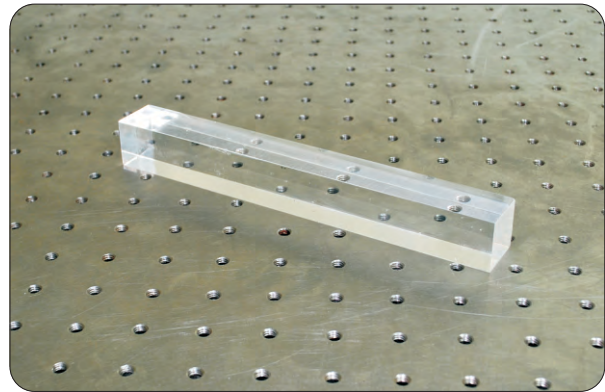

**11. Diode Laser with Power supply**

Input ..... 230V AC / 50 Hz  
Output power ..... 5mW  
Wavelength ..... 650nm



**12. Pinhole Photo detector with O/P measurement unit**

Input ..... 230V AC / 50 Hz  
Detector Type ..... Photo transistor  
Pinhole Diameter ..... 0.7 mm  
Range ..... 0.0 - 200  $\mu$ A &  
0.0 - 200 mA



**13. FC Connector Adapter**

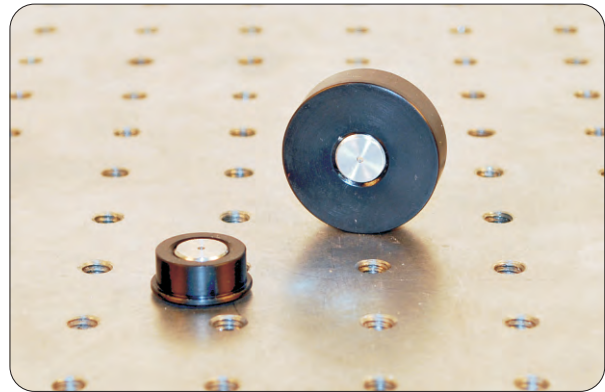

**14. Rotation stage with fiber chuck**

Rotation ..... 0 - 360°

Resolution ..... 2°

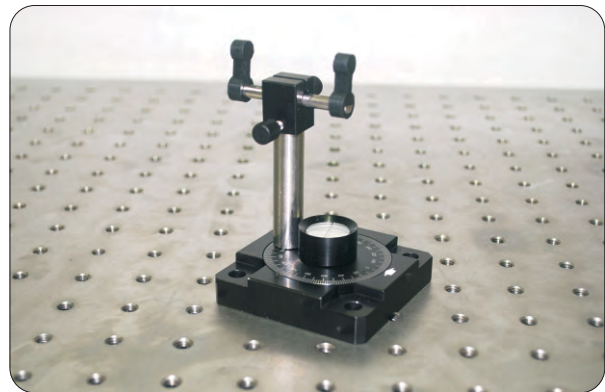

**15. Thumb Screws**





## Maintenance Notes

- Always keep the equipment in a moisture and dust free atmosphere.
- Do not touch the active region of optical components with bare hands.
- 'Switch on' all the electronic devices used in this experiment at least once in a week.

## Technical Support

Before you call the HOLMARC Technical Support staff, kindly gather the following information:

- Title and model number (usually listed on the label)
- Approximate age of apparatus
- Detailed description of the problem / sequence of events
- Have the manual in hand to discuss your query

## Feedback

If you have any comments regarding our product or manual, please let us know. If you have any suggestions on alternate experiments or find a problem in the manual, kindly inform us. HOLMARC appreciates any customer feedback. Your inputs help us evaluate and improve our product.

For technical support, contact us at  
E-mail: [sales@holmarc.com](mailto:sales@holmarc.com)  
Web: [www.holmarc.com](http://www.holmarc.com)

■ ■ Mechanical Drawing

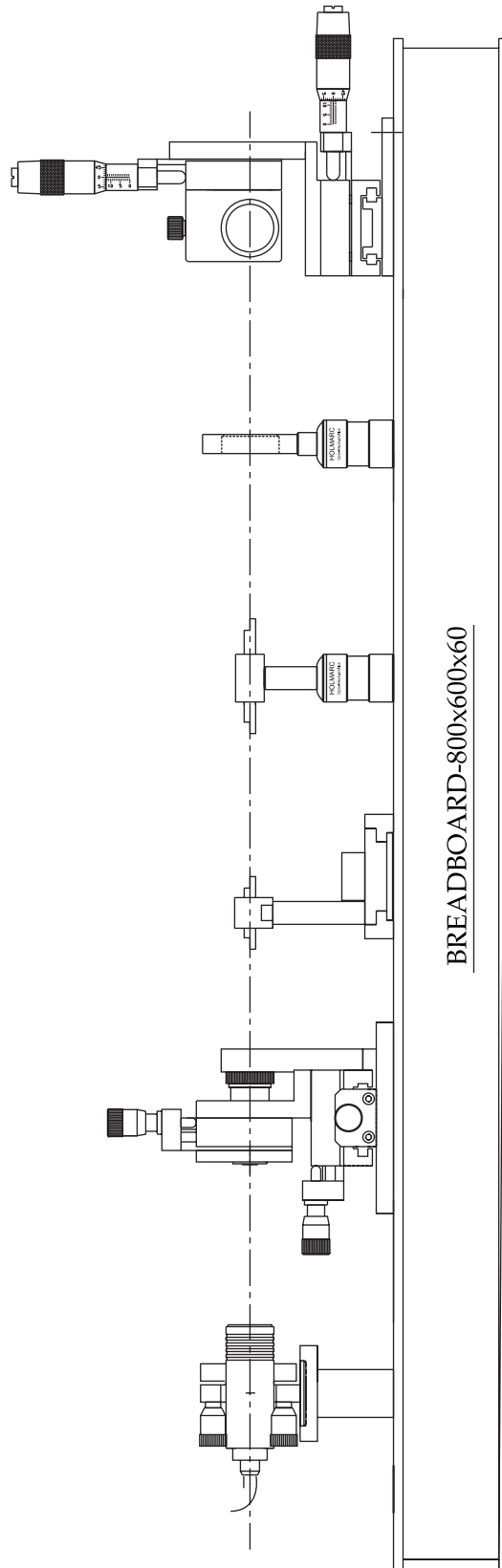

## ■ ■ Holmarc Limited Warranty

Every Holmarc Instruments and its accessories are warranted by HOLMARC OPTO-MECHATRONICS LTD for a period of ONE YEAR from the date of original purchase.

Holmarc will repair or replace a product, or part thereof, found by Holmarc to be defective, provided the defective part is returned to Holmarc, with proof of purchase.

This warranty applies to the original purchaser and our distributors and is non-transferable.

Each returned part or product must include a written statement detailing the nature of the claimed defect, as well as the end user's name, address, and phone number.

This warranty is not valid in cases where the product has been abused or mishandled, where unauthorized repairs have been attempted or performed, or where depreciation of the product is due to normal wear-and-tear.

Holmarc specifically disclaims special, indirect, or consequential damages or lost profit which may result from a breach of this warranty. Any implied warranties which cannot be disclaimed are hereby limited to a term of one year from the date of original retail purchase.

Holmarc reserves the right to change product specifications or to discontinue products without notice.

Please refer our [commercial invoice](#) for warranty claim.

(Authorized Signatory)

